

POWER MANAGEMENT

Description

The SC4502/SC4502H is a high-frequency current-mode step-up switching regulator with an integrated 1.4A power transistor. Its high switching frequency (programmable up to 2MHz) allows the use of tiny surface-mount external passive components. Programmable soft-start eliminates high inrush current during start-up. The internal switch is rated at 32V (40V for the SC4502H) making the converter suitable for high voltage applications such as Boost, SEPIC and Flyback.

The operating frequency of the SC4502/SC4502H can be set with an external resistor. The ability to set the operating frequency gives the SC4502/SC4502H design flexibilities. A dedicated COMP pin allows optimization of the loop response. The SC4502/SC4502H is available in thermally enhanced 10-pin MLPD package.

Features

- ◆ Low saturation voltage switch: 210mV (250mV for the SC4502H)
- ◆ Constant switching frequency current-mode control
- ◆ Programmable switching frequency up to 2MHz
- ◆ Soft-Start function
- ◆ Input voltage ranges from 1.4V to 16V
- ◆ Output voltage up to 32V (40V for the SC4502H)
- ◆ Low shutdown current
- ◆ Adjustable undervoltage lockout threshold
- ◆ Small low-profile thermally enhanced lead free package. This product is fully WEEE and RoHS compliant.

Applications

- ◆ Flat screen LCD bias supplies
- ◆ TFT bias supplies
- ◆ XDSL power supplies
- ◆ Medical equipment
- ◆ Digital video cameras
- ◆ Portables devices
- ◆ White LED power supplies

Typical Application Circuit

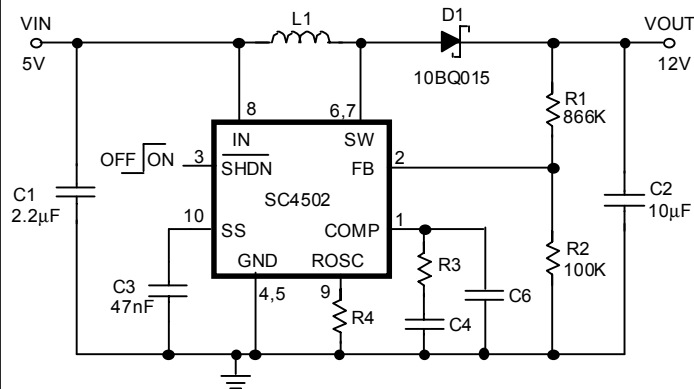

All Capacitors are Ceramic.

f (MHz)	R _s (KΩ)	R _i (KΩ)	C ₄ (pF)	C ₆ (pF)	L ₁ (µH)
0.7	33.2	23.7	1500	-	10.5 (Falco D08019)
1.4	59.0	9.53	560	-	5.3 (Sumida CDRH5D28)
2	73.2	5.36	330	22	3.3 (Coilcraft D01813P)

Figure 1(a). 5V to 12V Boost Converter.

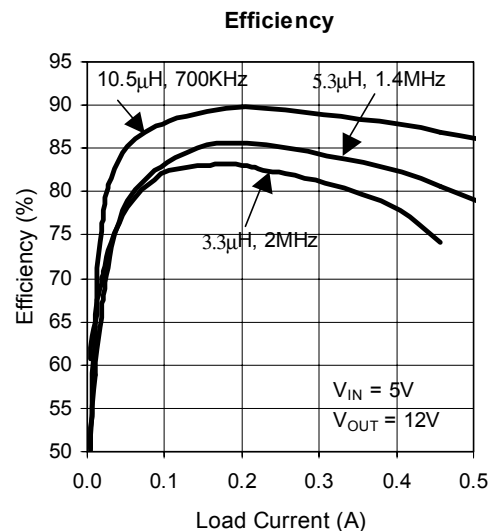

Figure 1(b). Efficiencies of 5V to 12V Boost Converters at 700KHz, 1.4MHz and 2MHz.

POWER MANAGEMENT
Absolute Maximum Rating

Exceeding the specifications below may result in permanent damage to the device, or device malfunction. Operation outside of the parameters specified in the Electrical Characteristics section is not implied.

Parameter	Symbol	Typ	Units
Supply Voltage	V_{IN}	-0.3 to 16	V
SW Voltage	V_{SW}	-0.3 to 32	V
SW Voltage (SC4502H)	V_{SW}	-0.3 to 40	V
FB Voltages	V_{FB}	-0.3 to 2.5	V
$\overline{\text{SHDN}}$ Voltage	$V_{\overline{\text{SHDN}}}$	-0.3 to $V_{IN} + 1$	V
Operating Temperature Range	T_A	-40 to +85	°C
Thermal Resistance Junction to Ambient (MLPD-10)	θ_{JA}	40	°C/W
Maximum Junction Temperature	T_J	160	°C
Storage Temperature Range	T_{STG}	-65 to +150	°C
Lead Temperature (Soldering)10 sec	T_{LEAD}	260	°C
ESD Rating (Human Body Model)	ESD	2000	V

Electrical Characteristics

Unless other specified: $V_{IN} = 2V$, $\overline{\text{SHDN}} = 1.5V$, $R_{osc} = 7.68k\Omega$, $-40^\circ\text{C} < T_A = T_J < 85^\circ\text{C}$

Parameter	Test Conditions	Min	Typ	Max	Unit
Minimum Operating Voltage			1.3	1.4	V
Maximum Operating Voltage				16	V
Feedback Voltage	$T_A = 25^\circ\text{C}$	1.224	1.242	1.260	V
	$-40^\circ\text{C} < T_A < 85^\circ\text{C}$	1.217		1.267	V
Feedback Voltage Line Regulation	$1.5V < V_{IN} < 16V$		0.01		%
FB Pin Bias Current			40	80	nA
Error Amplifier Transconductance			60		$\mu\Omega^{-1}$
Error Amplifier Open-Loop Gain			49		dB
COMP Source Current	$V_{FB} = 1.1V$		5		μA
COMP Sink Current	$V_{FB} = 1.4V$		5		μA
V_{IN} Quiescent Supply Current	$V_{\overline{\text{SHDN}}} = 1.5V$, $V_{\text{COMP}} = 0$ (Not Switching)		1.1	1.6	mA
V_{IN} Supply Current in Shutdown	$V_{\overline{\text{SHDN}}} = 0$		10	18	μA
Switching Frequency		1.3	1.5	1.7	MHz
Maximum Duty Cycle		85	90		%
Minimum Duty Cycle				0	%
Switch Current Limit		1.4	2		A
Switch Saturation Voltage	$I_{SW} = 1.3A$		210	340	mV
Switch Saturation Voltage (SC4502H)	$I_{SW} = 1.3A$		250	390	mV

POWER MANAGEMENT
Electrical Characteristics (Cont.)

 Unless other specified: $V_{IN} = 2V$, $\overline{SHDN} = 1.5V$, $R_{OSC} = 7.68k\Omega$, $-40^{\circ}C < T_A = T_J < 85^{\circ}C$

Parameter	Test Conditions	Min	Typ	Max	Unit
Switch Leakage Current	$V_{SW} = 5V$		0.01	1	mA
Shutdown Threshold Voltage		1.02	1.1	1.18	V
Shutdown Pin Current	$V_{SHDN} = 1.2V$		-4.6		μA
	$V_{SHDN} = 0$		0	0.1	μA
Soft-Start Charging Current	$V_{SS} = 0.3V$		1.5		μA
Thermal Shutdown Temperature			160		$^{\circ}C$
Thermal Shutdown Hysteresis			10		$^{\circ}C$

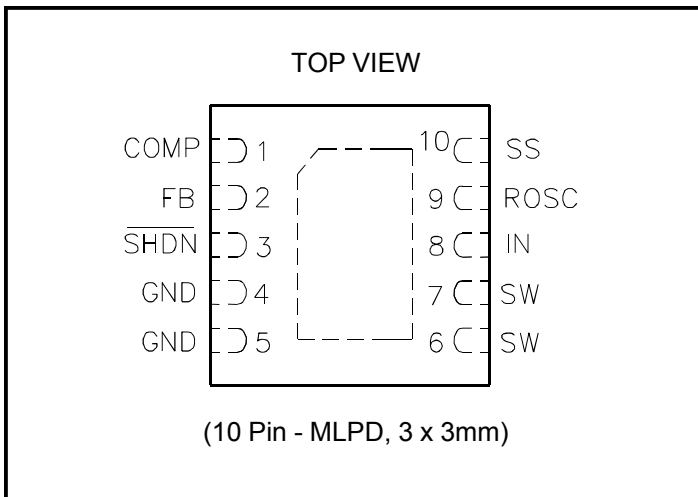
Pin Configurations

Ordering Information

Device ⁽¹⁾⁽²⁾	Package	Temp. Range(T_A)
SC4502MLTRT	MLPD-10	-40 to 85 $^{\circ}C$
SC4502HMLTRT	MLPD-10	-40 to 85 $^{\circ}C$
SC4502EVB	Evaluation Board	
SC4502HEVB	Evaluation Board	

Notes:

- (1) Only available in tape and reel packaging. A reel contains 3000 devices for MLP package.
- (2) Lead free product. This product is fully WEEE and RoHS compliant.

POWER MANAGEMENT

Pin Descriptions

Pin	Pin Name	Pin Function
1	COMP	The output of the internal transconductance error amplifier. This pin is used for loop compensation.
2	FB	The inverting input of the error amplifier. Tie to an external resistive divider to set the output voltage.
3	SHDN	Shutdown Pin. The accurate 1.1V shutdown threshold and the 4.6uA shutdown pin current hysteresis allow the user to set the undervoltage lockout threshold and hysteresis for the switching regulator. Pulling this pin below 0.1V causes the converter to shut down to low quiescent current. Tie this pin to IN if the UVLO and the shutdown features are not used. This pin should not be left floating.
4,5	GND	Ground. Tie both pins to the ground plane. Pins 4 and 5 are not internally connected.
6,7	SW	Collector of the internal power transistor. Connect to the boost inductor and the rectifying diode.
8	IN	Power Supply Pin. Bypassed with capacitors close to the pin.
9	ROSC	A resistor from this pin to the ground sets the switching frequency.
10	SS	Soft-Start Pin. A capacitor from this pin to the ground lengthens the start-up time and reduces start-up current.
	Exposed Pad	The exposed pad must be soldered to the ground plane on the PCB for good thermal conduction.

Block Diagram

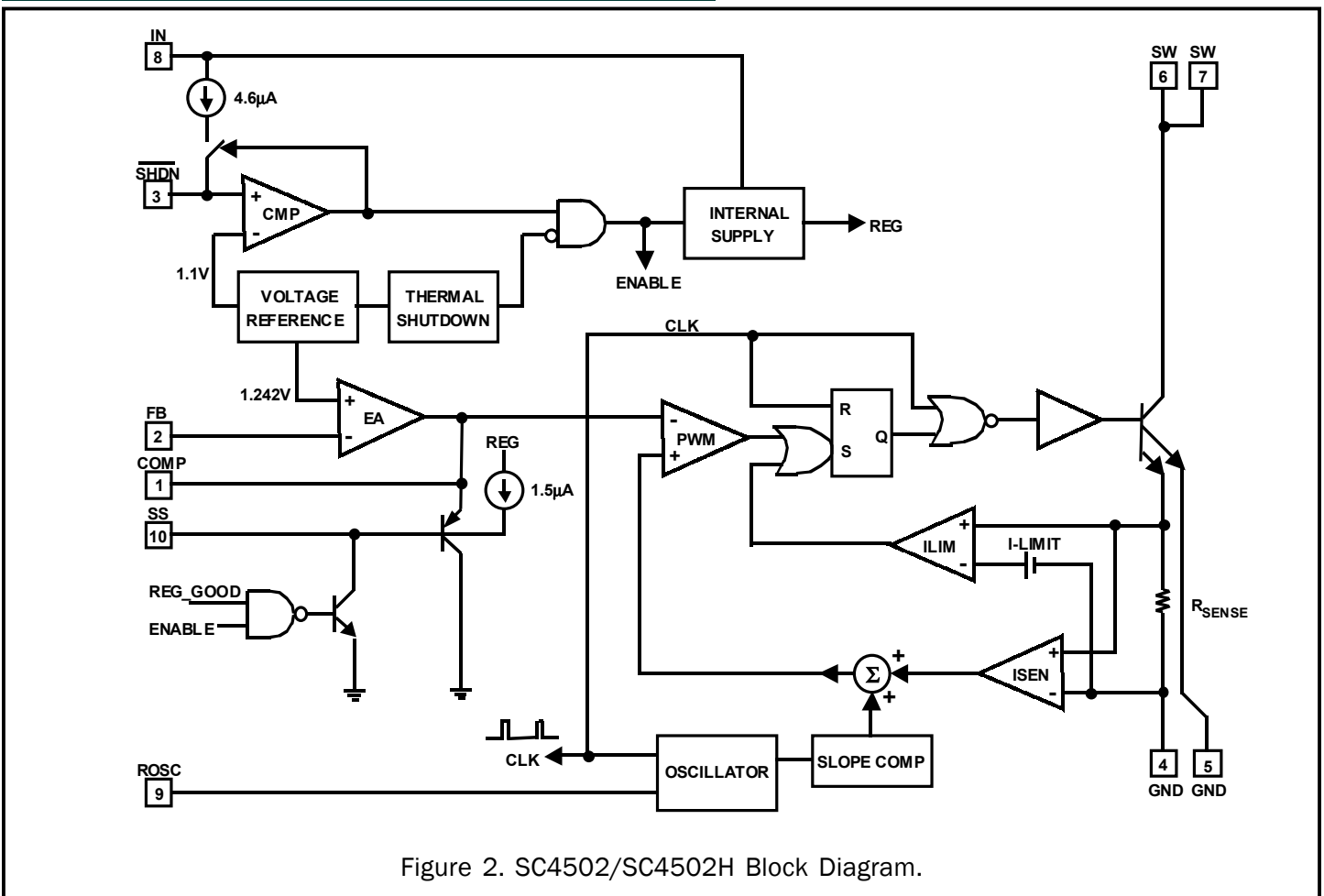
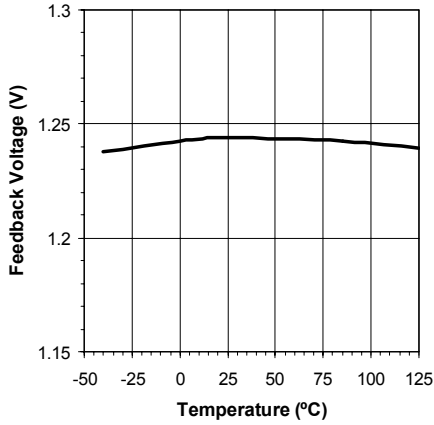

Figure 2. SC4502/SC4502H Block Diagram.

POWER MANAGEMENT

Typical Characteristics

Feedback Voltage vs Temperature



R_{OSC} vs Switching Frequency

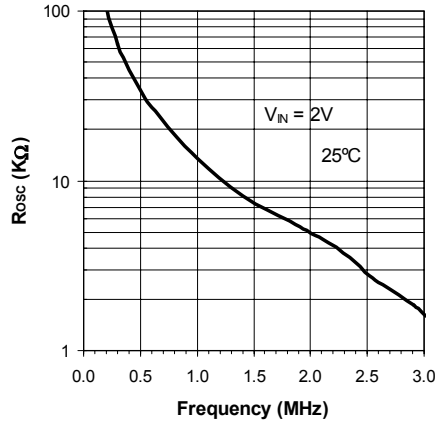

Switching Frequency vs Temperature

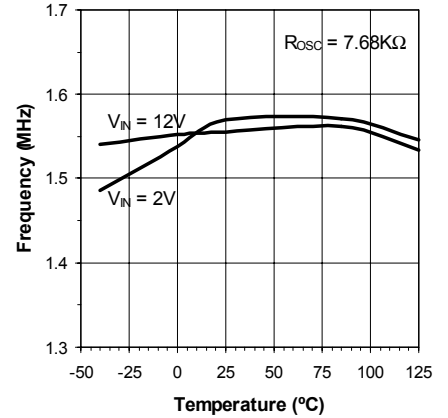

Switch Saturation Voltage vs Switch Current

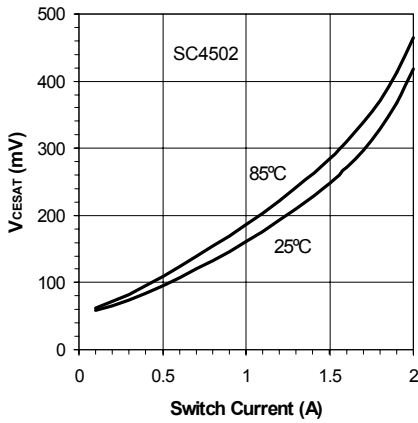

Switch Saturation Voltage vs Switch Current

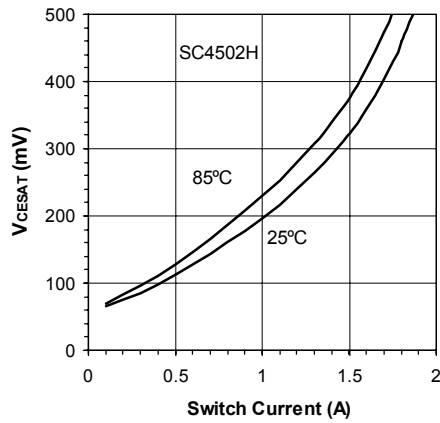

Minimum V_{IN} vs Temperature

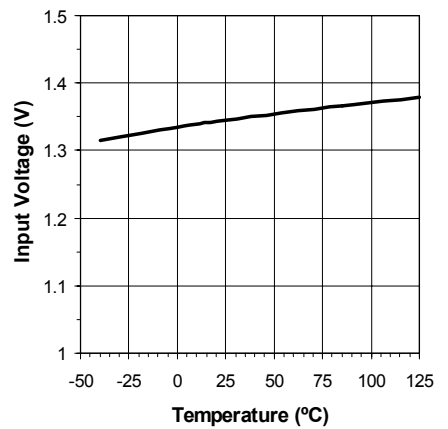

V_{IN} Quiescent Current vs Temperature

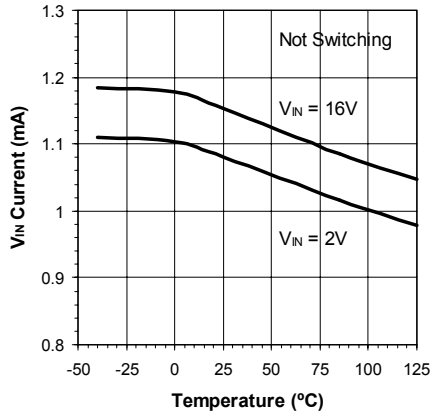

V_{IN} Current in Shutdown vs Input Voltage

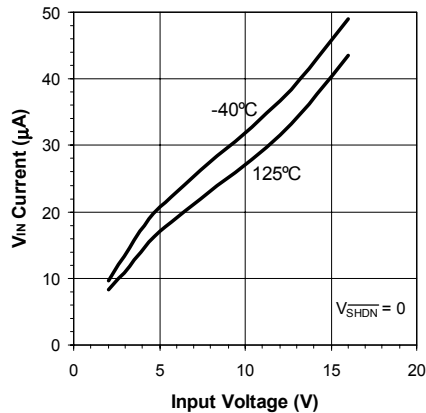

Shutdown Threshold vs Temperature

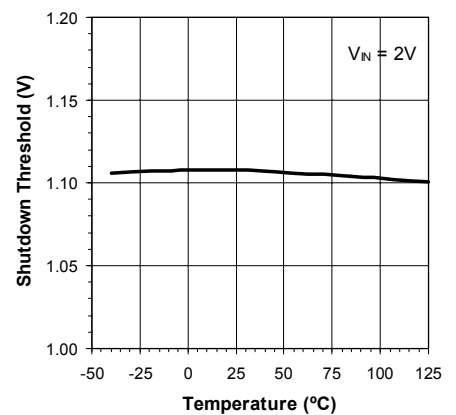

POWER MANAGEMENT

Typical Characteristics

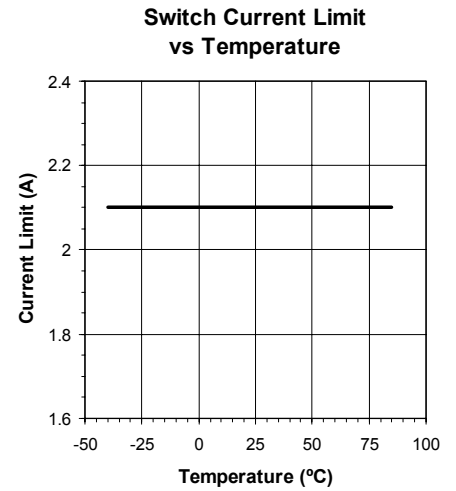
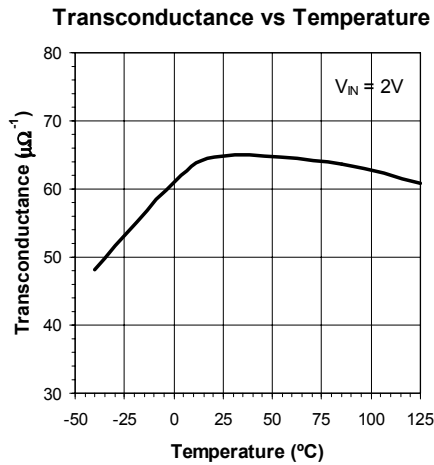
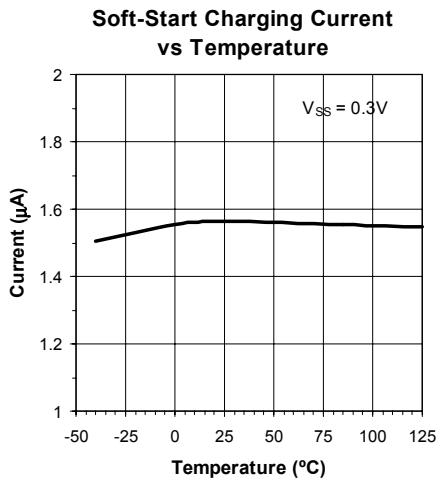
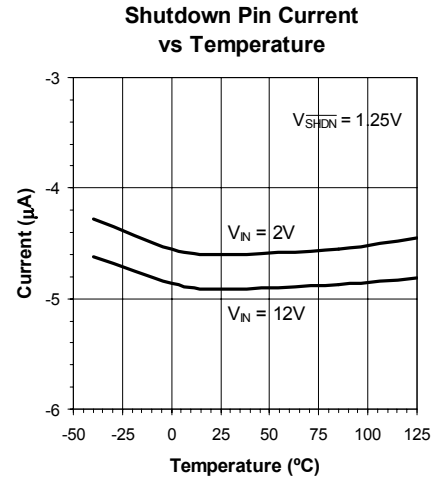
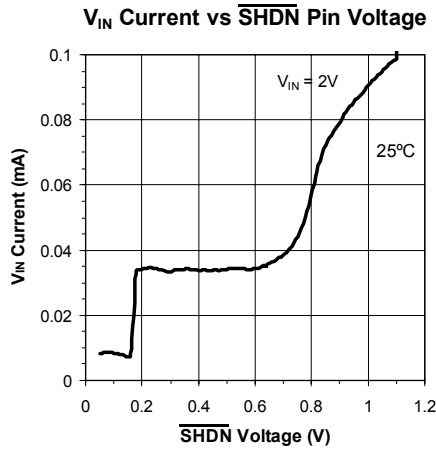
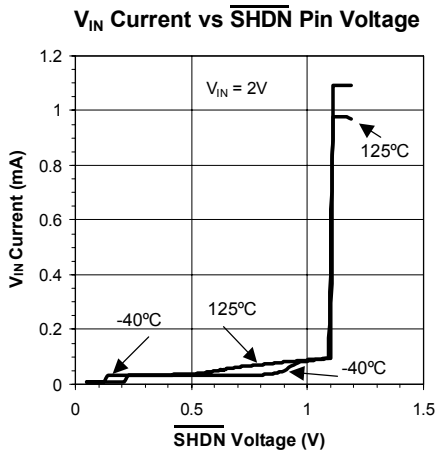

The SC4502/SC4502H is a programmable constant-frequency peak current-mode step-up switching regulator with an integrated power transistor. As shown in the block diagram in Figure 2, the power transistor is turned on at the trailing edge of the clock. Switch current is sensed with an integrated sense resistor. The sensed current signal is summed with the slope-compensating ramp before compared to the output of the error amplifier EA. The PWM comparator trip point determines the switch turn-on pulse width. The current-limit comparator ILIM turns off the power switch when the switch current exceeds the 2A current-limit threshold. ILIM therefore provides cycle-by-cycle current limit. Current-limit is not affected by slope compensation because the current limit comparator ILIM is not in the PWM signal path.

Current-mode switching regulators utilize a dual-loop feedback control system. In the SC4502/SC4502H the amplifier output COMP controls the peak inductor current. This is the inner current loop. The double reactive poles of the output LC filter are reduced to a single real pole by the inner current loop, easing loop compensation. Fast transient response can be obtained with a simple Type-2 compensation network. In the outer loop, the error amplifier regulates the output voltage.

The switching frequency of the SC4502/SC4502H can be programmed up to 2MHz with an external resistor from the ROSC pin to the ground. For converters requiring extremely low or high duty cycles, the operating frequency can be lowered to maintain the necessary minimum on time or the minimum off time.

The SC4502/SC4502H requires a minimum input of 1.4V to operate. A voltage higher than 1.1V at the shutdown pin enables the internal linear regulator REG in the SC4502/SC4502H. After V_{REG} becomes valid, the soft-start capacitor is charged with a 1.5 μ A current source. A PNP transistor clamps the output of the error amplifier as the soft-start capacitor voltage rises. Since the COMP voltage controls the peak inductor current, the inductor current is ramped gradually during soft-start, preventing high input start-up current. Under fault conditions ($V_{IN} < 1.4V$ or over temperature) or when the shutdown pin is pulled below 1.1V, the soft-start capacitor is discharged to ground. Pulling the shutdown pin below 0.1V reduces the total supply current to 10 μ A.

Setting the Output Voltage

An external resistive divider R_1 and R_2 with its center tap tied to the FB pin (Figure 3) sets the output voltage.

$$R_1 = R_2 \left(\frac{V_{OUT}}{1.242V} - 1 \right) \quad (1)$$

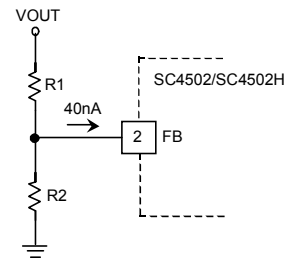

Figure 3. The Output Voltage is set with a Resistive Divider

The input bias current of the error amplifier will introduce an error of:

$$\frac{\Delta V_{OUT}}{V_{OUT}} = \frac{40nA \cdot (R_1 // R_2) \cdot 100}{1.242V} \% \quad (2)$$

The percentage error of a $V_{OUT} = 5V$ converter with $R_1 = 100K\Omega$ and $R_2 = 301K\Omega$ is

$$\frac{\Delta V_{OUT}}{V_{OUT}} = \frac{40nA \cdot (100K\Omega // 301K\Omega) \cdot 100}{1.242V} = 0.24\%$$

Operating Frequency and Efficiency

Switching frequency of SC4502/SC4502H is set with an external resistor from the ROSC pin to the ground. A graph showing the relationship between R_{OSC} and switching frequency is given in the "Typical Characteristics".

High frequency operation reduces the size of passive components but switching losses are higher. The efficiencies of 5V to 12V converters operating at 700KHz, 1.4MHz and 2MHz are plotted in Figure 1(b) for SC4502.

Duty Cycle

The duty cycle D of a boost converter in continuous conduction mode is:

POWER MANAGEMENT

Applications Information

$$D = \frac{1 - \frac{V_{IN}}{V_{OUT} + V_D}}{1 - \frac{V_{CESAT}}{V_{OUT} + V_D}} \quad (3)$$

where V_{CESAT} is the switch saturation voltage and V_D is the voltage drop across the rectifying diode.

Maximum Output Current

In a boost switching regulator the inductor is connected to the input. The DC inductor current is the input current. When the power switch is turned on, the inductor current flows through the switch. When the power switch is off, the inductor current flows through the rectifying diode to the output. The maximum output current is the average diode current. The diode current waveform is trapezoidal with pulse width $(1 - D)T$ (Figure 4). The output current available from a boost converter therefore depends on the converter operating duty cycle. The power switch current in the SC4502/SC4502H is internally limited to 2A. This is also the maximum inductor or the input current. By estimating the conduction losses in both the switch and the rectifying diode, an expression of the maximum available output current of a boost converter can be derived as follows:

$$I_{OUTMAX} = \frac{I_{LIM} V_{IN}}{V_{OUT}} \left[1 - \frac{D}{45} - \frac{V_D - D(V_D - V_{CESAT})}{V_{IN}} \right] \quad (4)$$

where I_{LIM} is the switch current limit.

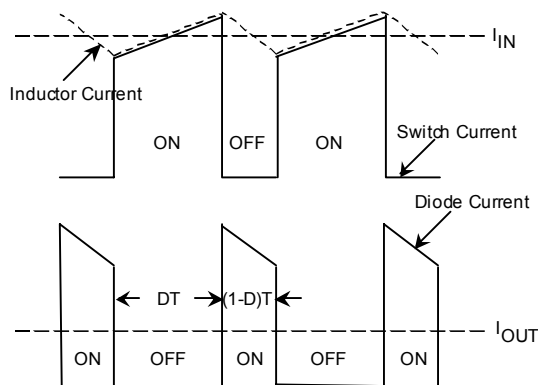

Figure 4. Current Waveforms in a Boost Regulator

It is worth noting that I_{OUTMAX} is directly proportional to the ratio of $\frac{V_{IN}}{V_{OUT}}$. Equation (4) over-estimates the maximum output current at high frequencies (>1MHz) since switching losses are neglected in its derivation. Nevertheless it is a useful first-order approximation.

Using $V_{CESAT} = 0.3V$, $V_D = 0.5V$ and $I_{LIM} = 1.4A$ in (3) and (4), the maximum output currents for three V_{IN} and V_{OUT} combinations are shown in Table 1.

V_{IN} (V)	V_{OUT} (V)	D	I_{OUTMAX} (A)
2.5	12	0.820	0.25
3.3	5	0.423	0.80
5	12	0.615	0.53

Table 1. Calculated Maximum Output Current [Equation (4)]

Considerations for High Frequency Operation

The operating duty cycle of a boost converter decreases as V_{IN} approaches V_{OUT} . The PWM modulating ramp in a current-mode switching regulator is the sensed current signal. This current ramp is absent unless the switch is turned on. The intersection of this ramp with the output of the voltage feedback error amplifier determines the switch pulse width. The propagation delay time required to immediately turn off the switch after it is turned on is the minimum switch on time. Regulator closed-loop measurement shows that the SC4502/SC4502H has a minimum on time of about 150ns at room temperature. The power switch in the SC4502/SC4502H is either not turned on at all or on for at least 150ns. If the required switch on time is shorter than the minimum on time, the regulator will either skip cycles or it will start to jitter.

Example: Determine the maximum operating frequency of a Li-ion cell to 5V converter using the SC4502. Assuming that $V_D = 0.5V$, $V_{CESAT} = 0.3V$ and $V_{IN} = 2.6V - 4.2V$, the minimum duty ratio can be found using (3).

$$D_{MIN} = \frac{1 - \frac{4.2}{5 + 0.5}}{1 - \frac{0.3}{5 + 0.5}} = 0.25$$

POWER MANAGEMENT
Applications Information

The absolute maximum operating frequency of the converter is therefore $\frac{D_{MIN}}{150ns} = \frac{0.25}{150ns} = 1.67MHz$. The actual operating frequency needs to be lower to allow for modulating headroom.

The power transistor inside the SC4502/SC4502H is turned off every switching cycle for an interval determined by the discharge time of the oscillator ramp plus the propagation delay of the power switch. This minimum off time limits the maximum duty cycle of the regulator at a given switching frequency. A boost converter with high

$\frac{V_{OUT}}{V_{IN}}$ ratio requires long switch on time and high duty cycle.

If the required duty cycle is higher than the attainable maximum, the converter will operate in dropout. (Dropout is the condition in which the regulator cannot attain its set output voltage below current limit.)

The minimum off times of closed-loop boost converters set to various output voltages were measured by lowering their input voltages until dropout occurs. It was found that the minimum off time of the SC4502/SC4502H ranged from 80ns to 110ns at room temperature.

Beware of dropout while operating at very low input voltages (1.5V-2V) with off time approaching 110ns. Shorten the PCB trace between the power source and the device input pin, as line drop may be a significant percentage of the input voltage. A regulator in dropout may appear as if it is in current limit. The cycle-by-cycle current limit of the SC4502/SC4502H is duty-cycle and input voltage invariant and is typically 2A. If the switch current limit is not at least 1.4A, then the converter is likely in dropout. The switching frequency should then be lowered to improve controllability.

Both the minimum on time and the minimum off time reduce control range of the PWM regulator. Bench measurement showed that reduced modulating range started to be a problem at frequencies over 2MHz. Although the oscillator is capable of running well above 2MHz, controllability limits the maximum operating frequency.

Inductor Selection

The inductor ripple current ΔI_L of a boost converter

operating in continuous-conduction mode is

$$\Delta I_L = \frac{D \cdot (V_{IN} - V_{CESAT})}{f \cdot L} \quad (5)$$

where f is the switching frequency and L is the inductance.

Substituting (3) into (5) and neglecting V_{CESAT} ,

$$\Delta I_L = \frac{V_{IN}}{f \cdot L} \left(1 - \frac{V_{IN}}{V_{OUT} + V_D} \right) \quad (6)$$

In peak current-mode control, the slope of the modulating (sensed switch current) ramp should be steep enough to lessen jittery tendency but not so steep that large flux swing decreases efficiency. Inductor ripple current ΔI_L between 25%-40% of the peak inductor current limit is a good compromise. Inductors so chosen are optimized in size and DCR. Setting $\Delta I_L = 0.3 \cdot (1.4A) = 0.42A$, $V_D = 0.5V$ in (6),

$$L = \frac{V_{IN}}{f \cdot \Delta I_L} \left(1 - \frac{V_{IN}}{V_{OUT} + V_D} \right) = \frac{V_{IN}}{0.42A \cdot f} \left(1 - \frac{V_{IN}}{V_{OUT} + 0.5V} \right) \quad (7)$$

where L is in μH and f is in MHz.

Equation (6) shows that for a given V_{OUT} , ΔI_L is the highest

when $V_{IN} = \frac{(V_{OUT} + V_D)}{2}$. If V_{IN} varies over a wide range, then choose L based on the nominal input voltage.

The saturation current of the inductor should be 20%-30% higher than the peak current limit (2A). Low-cost powder iron cores are not suitable for high-frequency switching power supplies due to their high core losses. Inductors with ferrite cores should be used.

Input Capacitor

The input current in a boost converter is the inductor current, which is continuous with low RMS current ripples. A 2.2 μF -4.7 μF ceramic input capacitor is adequate for most applications.

Output Capacitor

Both ceramic and low ESR tantalum capacitors can be used as output filtering capacitors. Multi-layer ceramic capacitors, due to their extremely low ESR (<5m Ω), are the best choice. Use ceramic capacitors with stable

POWER MANAGEMENT
Applications Information

temperature and voltage characteristics. One may be tempted to use Z5U and Y5V ceramic capacitors for output filtering because of their high capacitance and small sizes. However these types of capacitors have high temperature and high voltage coefficients. For example, the capacitance of a Z5U capacitor can drop below 60% of its room temperature value at -25°C and 90°C . X5R ceramic capacitors, which have stable temperature and voltage coefficients, are the preferred type.

The diode current waveform in Figure 4 is discontinuous with high ripple-content. In a buck converter, the inductor ripple current ΔI_L determines the output ripple voltage. The output ripple voltage of a boost regulator is however much higher and is determined by the absolute value of the inductor current. Decreasing the inductor ripple current does not appreciably reduce the output ripple voltage. The current flowing in the output filter capacitor is the difference between the diode current and the output current. This capacitor current has a RMS value of:

$$I_{\text{OUT}} \sqrt{\frac{V_{\text{OUT}}}{V_{\text{IN}}} - 1} \quad (8)$$

If a tantalum capacitor is used, then its ripple current rating in addition to its ESR will need to be considered.

When the switch is turned on, the output capacitor supplies the load current I_{OUT} (Figure 4). The output ripple voltage due to charging and discharging of the output capacitor is therefore:

$$\Delta V_{\text{OUT}} = \frac{I_{\text{OUT}} \cdot D \cdot T}{C_{\text{OUT}}} \quad (9)$$

For most applications, a $10\mu\text{F}$ - $22\mu\text{F}$ ceramic capacitor is sufficient for output filtering. It is worth noting that the output ripple voltage due to discharging of a $10\mu\text{F}$ ceramic capacitor (9) is higher than that due to its ESR.

Rectifying Diode

For high efficiency, Schottky barrier diodes should be used as rectifying diodes for the SC4502/SC4502H. These diodes should have a RMS current rating between 0.5A and 1A with a reverse blocking voltage of at least a few

Volts higher than the output voltage. For switching regulators operating at low duty cycles (i.e. low output voltage to input voltage conversion ratios), it is beneficial to use rectifying diodes with somewhat higher RMS current ratings (thus lower forward voltages). This is because the diode conduction interval is much longer than that of the transistor. Converter efficiency will be improved if the voltage drop across the diode is lower.

The rectifying diodes should be placed close to the SW pins of the SC4502/SC4502H to minimize ringing due to trace inductance. Surface-mount equivalents of 1N5817, 1N5819, MBRM120, MBR0520 (ON Semi) and 10BQ015, 10BQ040 (IRF) are all suitable.

Soft-Start

Soft-start prevents a DC-DC converter from drawing excessive current (equal to the switch current limit) from the power source during start up. If the soft-start time is made sufficiently long, then the output will enter regulation without overshoot. An external capacitor from the SS pin to the ground and an internal $1.5\mu\text{A}$ charging current source set the soft-start time. The soft-start voltage ramp at the SS pin clamps the error amplifier output. During regulator start-up, COMP voltage follows the SS voltage. The converter starts to switch when its COMP voltage exceeds 0.7V. The peak inductor current is gradually increased until the converter output comes into regulation. If the shutdown pin is forced below 1.1V or if a fault situation is detected, then the soft-start capacitor will be discharged to ground immediately.

The SS pin can be left open if soft-start is not required.

Shutdown

The input voltage and shutdown pin voltage must be greater than 1.4V and 1.1V respectively to enable the SC4502/SC4502H. Forcing the shutdown pin below 1.1V stops the SC4502/SC4502H from switching. Pulling this pin below 0.1V completely shuts off the SC4502/SC4502H. The total V_{IN} shutdown current decreases to $10\mu\text{A}$ at 2V. Figure 5 shows several ways of interfacing the control logic to the shutdown pin. Beware that the shutdown pin is a high impedance pin. It should always be driven from a low-impedance source or tied to a resistive divider. Floating the shutdown pin will result in undefined voltage. In Figure 5(c) the shutdown pin is driven from a logic

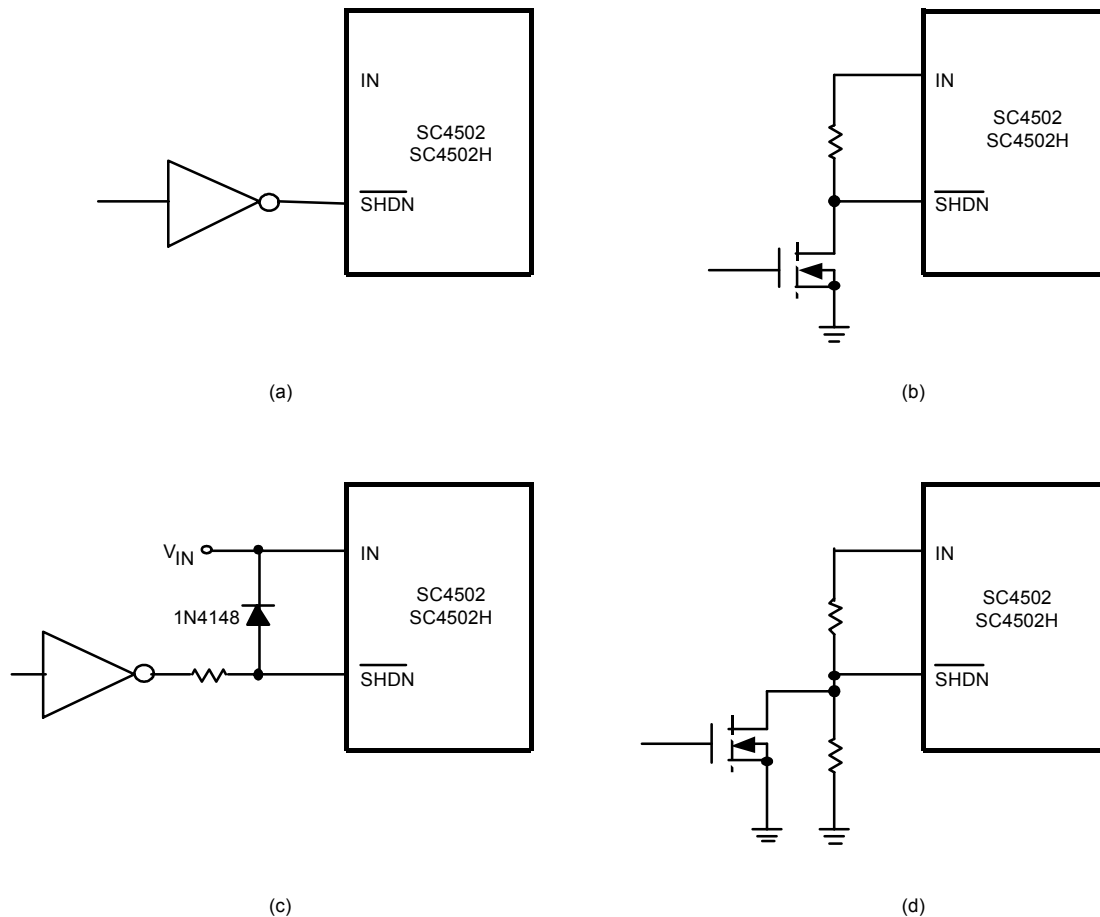

Figure 5. Methods of Driving the Shutdown Pin

(a) Directly Driven from a Logic Gate

 (b) Driven from an Open-drain N-channel MOSFET or an Open-Collector NPN Transistor ($V_{OL} < 0.1V$)

 (c) Driven from a Logic Gate with $V_{OH} > V_{IN}$

(d) Combining Shutdown with Programmed UVLO (See Section Below).

gate whose V_{OH} is higher than the supply voltage of the SC4502/SC4502H. The diode clamps the maximum shutdown pin voltage to one diode voltage above the input power supply.

Programming Undervoltage Lockout

The SC4502/SC4502H has an internal V_{IN} undervoltage lockout (UVLO) threshold of 1.4V. The transition from idle to switching is abrupt but there is no hysteresis. If the input voltage ramp rate is slow and the input bypass is limited, then sudden turn on of the power transistor will cause a dip in the line voltage. Switching will stop if V_{IN} falls below the internal UVLO threshold. The resulting output voltage rise may be non-monotonic. The 1.1V disable threshold of the SC4502/SC4502H can be used

in conjunction with a resistive voltage divider to raise the UVLO threshold and to add an UVLO hysteresis. Figure 6 shows the scheme. Both V_H and V_L (the desired upper and the lower UVLO threshold voltages) are determined by the 1.1V threshold crossings, V_H and V_L are therefore:

$$V_H = \left(1 + \frac{R_3}{R_4}\right) \cdot (1.1V)$$

$$V_L = V_H - V_{HYS} = V_H - I_{HYS}R_3 \quad (10)$$

Re-arranging,

$$R_3 = \frac{V_{HYS}}{I_{HYS}} \quad (11)$$

$$R_4 = \frac{R_3}{\frac{V_H}{1.1V} - 1} \quad (12)$$

POWER MANAGEMENT

Applications Information

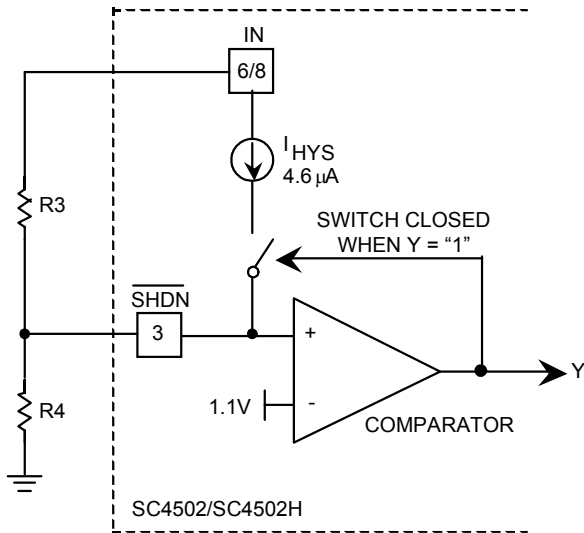

Figure 6. Programmable Hysteretic UVLO Circuit

with $V_L > 1.4V$.

Example: Increase the turn on voltage of a $V_{IN} = 3.3V$ boost converter from 1.4V to 2.75V.

Using $V_H = 2.75V$ and $R_4 = 100K\Omega$ in (12),

$$R_3 = 150K\Omega.$$

The resulting UVLO hysteresis is:

$$V_{HYS} = I_{HYS} R_3 = 4.6\mu A \cdot 150K\Omega = 0.69V$$

The turn off voltage is:

$$V_L = V_H - V_{HYS} = 2.75V - 0.69V = 2.06V > 1.4V.$$

Frequency Compensation

Figure 7 shows the equivalent circuit of a boost converter using the SC4502/SC4502H. The output filter capacitor and the load form an output pole at frequency:

$$\omega_{p2} = \frac{2 \cdot I_{OUT}}{V_{OUT} \cdot C_2} = \frac{2}{R_{OUT} \cdot C_2} \tag{13}$$

where C_2 is the output capacitance and $R_{OUT} = \frac{V_{OUT}}{I_{OUT}}$ is the equivalent load resistance.

The zero formed by C_2 and its equivalent series resistance (ESR) is neglected due to low ESR of the ceramic output capacitor.

There is also a right half plane (RHP) zero with angular frequency:

$$\omega_{z2} = \frac{R_{OUT} \cdot (1-D)^2}{L} \tag{14}$$

ω_{z2} decreases with increasing duty cycle D and increasing I_{OUT} . Using the 5V to 12V boost regulator (1.4MHz) in Figure 1(a) as an example,

$$R_{OUT} \geq \frac{5V}{0.5A} = 10\Omega$$

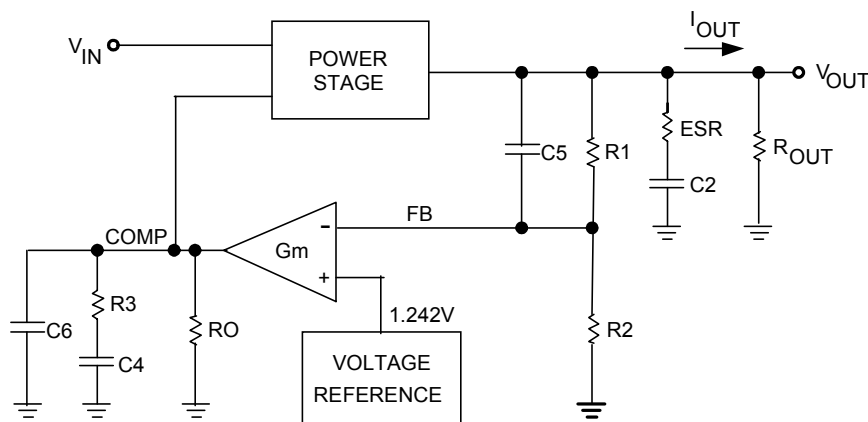

Figure 7. Simplified Block Diagram of a Boost Converter

POWER MANAGEMENT

Applications Information

$$D = \frac{1 - \frac{5}{12 + 0.5}}{1 - \frac{0.3}{12 + 0.5}} = 0.62$$

Therefore

$$\omega_{p2} \leq \frac{2}{(10\Omega) \cdot (10\mu F)} = 20\text{Krad/s}^{-1} \Rightarrow 3.18\text{KHz}$$

and

$$\omega_{z2} \geq \frac{10\Omega \cdot (1 - 0.62)^2}{5.3\mu H} = 272\text{Krad/s}^{-1} \Rightarrow 43.4\text{KHz}$$

The spacing between p_2 and z_2 is the closest when the converter is delivering the maximum output current from the lowest V_{IN} . This represents the worst-case compensation condition. Ignoring C_5 and C_6 for the moment, C_4 forms a low frequency pole with the equivalent output resistance R_o of the error amplifier:

$$R_o = \frac{\text{Amplifier Open Loop Gain}}{\text{Transconductance}} = \frac{49\text{dB}}{60\mu\Omega^{-1}} = 4.7\text{M}\Omega$$

$$\omega_{p1} = \frac{1}{R_o C_4} = \frac{1}{4.7\text{M}\Omega \cdot 560\text{pF}} = 380\text{ rad/s}^{-1} \Rightarrow 60\text{Hz}$$

C_4 and R_3 also forms a zero with angular frequency:

$$\omega_{z1} = \frac{1}{R_3 C_4} = \frac{1}{59\text{K}\Omega \cdot 560\text{pF}} = 30.3\text{ Krad/s}^{-1} \Rightarrow 4.8\text{KHz}$$

The poles p_1 , p_2 and the RHP zero z_2 all increase phase shift in the loop response. For stable operation, the overall loop gain should cross 0dB with -20dB/decade slope. Due to the presence of the RHP zero, the crossover frequency

should not be higher than $\frac{z_2}{3}$. Placing z_1 near p_2 nulls its effect and maximizes loop bandwidth. Thus

$$R_3 C_4 \approx \frac{V_{OUT} \cdot C_2}{2 \cdot I_{OUT(MAX)}} \tag{15}$$

R_3 determines the mid-band loop gain of the converter. Increasing R_3 increases the mid-band gain and the crossover frequency. However it reduces the phase margin. The values of R_3 and C_4 can be determined

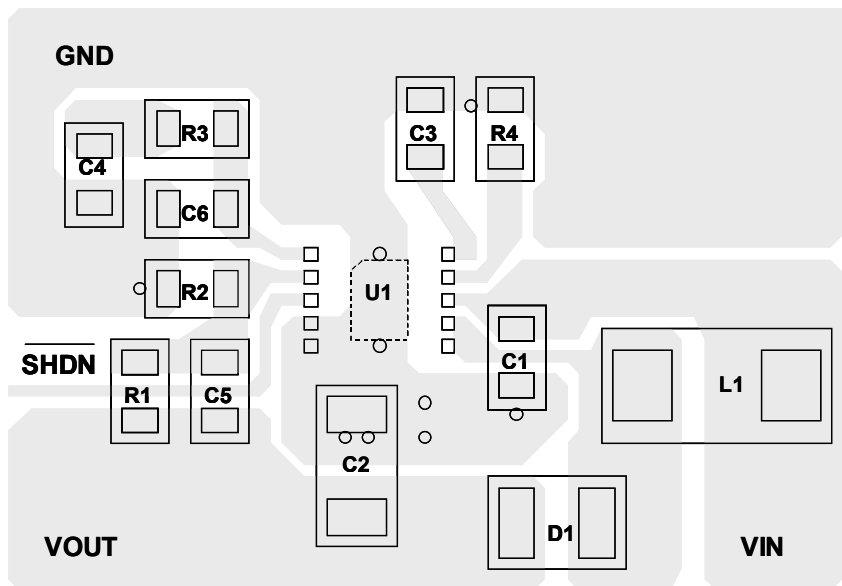

Figure 8. Suggested PCB Layout for the SC4502/SC4502H. Notice that there is no via directly under the device. All vias are 12mil in diameter.

POWER MANAGEMENT

Applications Information

empirically by observing the inductor current and the output voltage during load transient. Compensation is optimized when the largest R_3 and the smallest C_4 without producing ringing or excessive overshoot in its inductor current and output voltage are found. Figures 9(b), 10(c), 11(b) and 11(c) show load transient responses of empirically optimized DC-DC converters. In a battery-operated system, compensating for the minimum V_{IN} and the maximum load step will ensure stable operation over the entire input voltage range.

C_5 adds a feedforward zero to the loop response. In some cases, it improves the transient speed of the converter. C_6 rolls off the gain at high frequency. This helps to stabilize the loop. C_5 and C_6 are often not needed.

Board Layout Considerations

In a step-up switching regulator, the output filter capacitor, the main power switch and the rectifying diode carry switched currents with high di/dt. For jitter-free operation, the size of the loop formed by these components should be minimized. Since the power switch is integrated inside the SC4502/SC4502H, grounding the output filter capacitor next to the SC4502/SC4502H ground pin minimizes size of the high di/dt current loop.

The input bypass capacitors should also be placed close to the input pins. Shortening the trace at the SW node reduces the parasitic trace inductance. This not only reduces the EMI but also decreases the sizes of the switching voltage spikes and glitches.

Figure 8 shows how various external components are placed around the SC4502/SC4502H. The frequency-setting resistor should be placed near the ROOSC pin with a short ground trace on the PC board. These precautions reduce switching noise pickup at the ROOSC pin.

To achieve a junction to ambient thermal resistance (θ_{JA}) of 40°C/W, the exposed pad of the SC4502/SC4502H should be properly soldered to a large ground plane. Use only 12mil diameter vias in the ground plane if necessary. Avoid using larger vias under the device. Molten solder may seep through large vias during reflow, resulting in poor adhesion, poor thermal conductivity and low reliability.

Typical Application Circuits

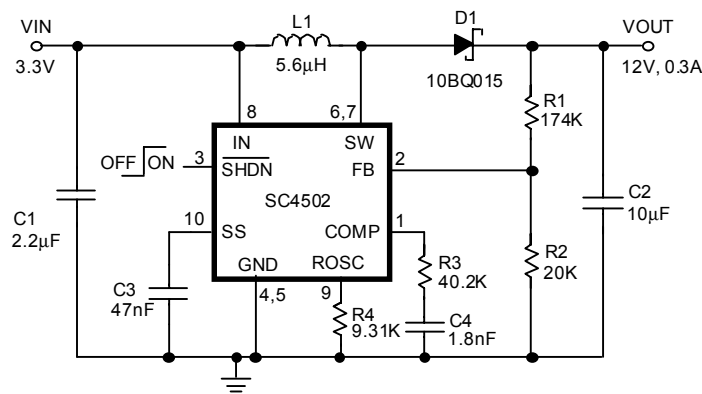

L1: Sumida CR43

Figure 9(a). 1.35 MHz All Ceramic Capacitor 3.3V to 12V Boost Converter.

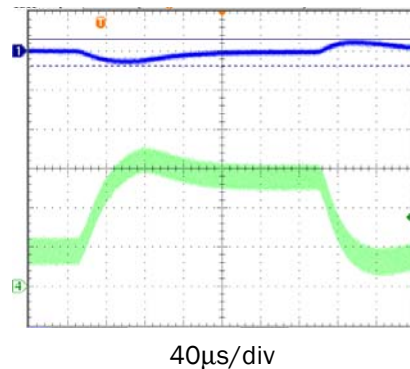

Upper Trace : Output Voltage, AC Coupled, 1V/div
Lower Trace : Inductor Current, 0.5A/div

Figure 9(b). Load Transient Response of the Circuit in Figure 9(a). I_{LOAD} is switched between 0.1A and 0.3A at 1A/µs.

POWER MANAGEMENT

Typical Application Circuits

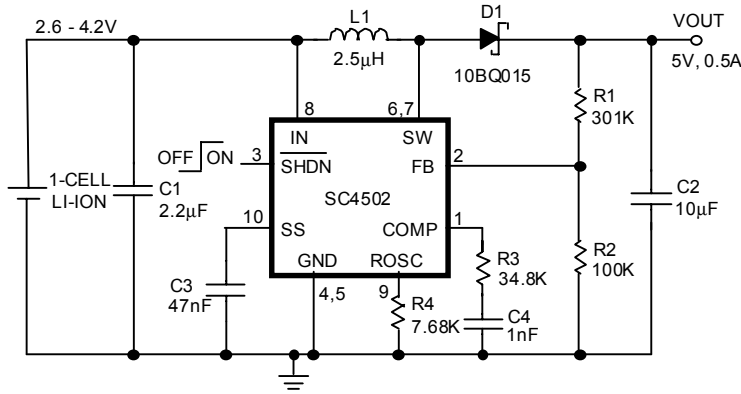

L1: Sumida CDRH5D28

Figure 10(a). 1.5 MHz All Ceramic Capacitor Single Li-ion Cell to 5V Boost Converter.

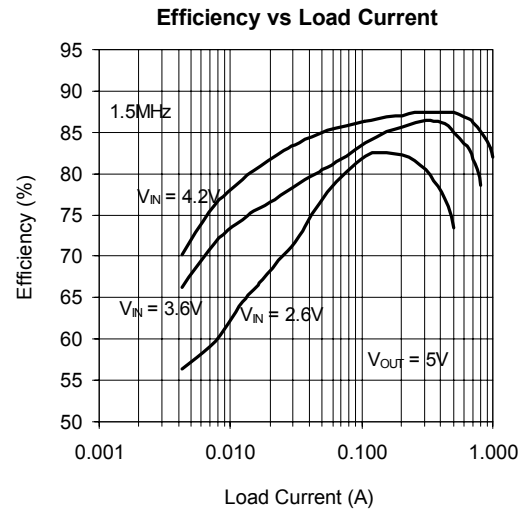
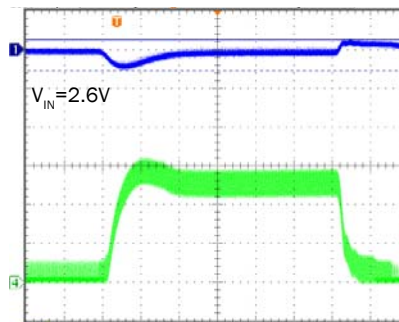

Figure 10(b). Efficiency of the Single Li-ion Cell to 5V Boost Converter in Figure 10(a).



40µs/div

Upper Trace : Output Voltage, AC Coupled, 0.5V/div
 Lower Trace : Inductor Current, 0.5A/div

Figure 10(c). Load Transient Response of the Circuit in Figure . 10(a). I_{LOAD} is switched between 90mA and 0.5A at 1A/µs.

POWER MANAGEMENT

Typical Application Circuits

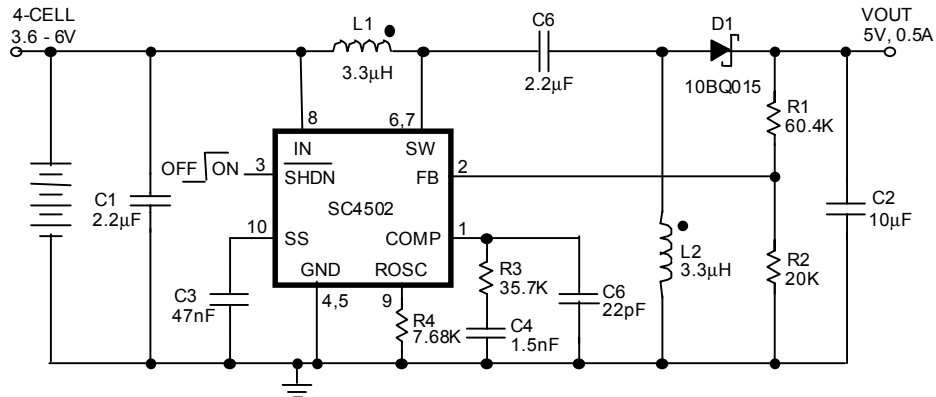

L1 and L2: Coiltronics DRQ73-3R3

Figure 11(a). 1.5 MHz All Ceramic Capacitor 4-Cell to 5V SEPIC Converter.

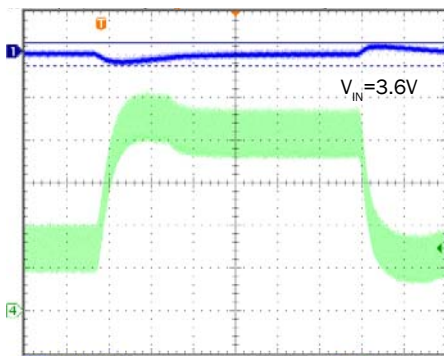

40µs/div

Upper Trace : Output Voltage, AC Coupled, 0.5V/div
Lower Trace : Input Inductor Current, 0.2A/div

Figure 11(b). Load Transient Response of the Circuit in Figure 11(a). I_{LOAD} is switched between 150mA and 450mA at 1A/µs.

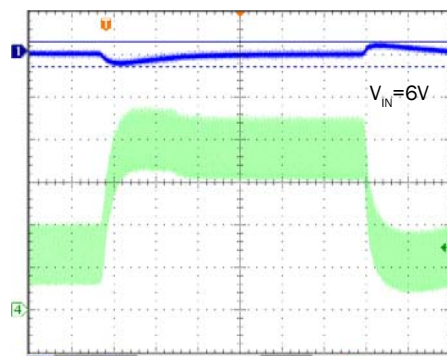

40µs/div

Upper Trace : Output Voltage, AC Coupled, 0.5V/div
Lower Trace : Input Inductor Current, 0.2A/div

Figure 11(c). Load Transient Response of the Circuit in Figure 11(a). I_{LOAD} is switched between 250mA and 700mA at 1A/µs.

POWER MANAGEMENT

Typical Application Circuits

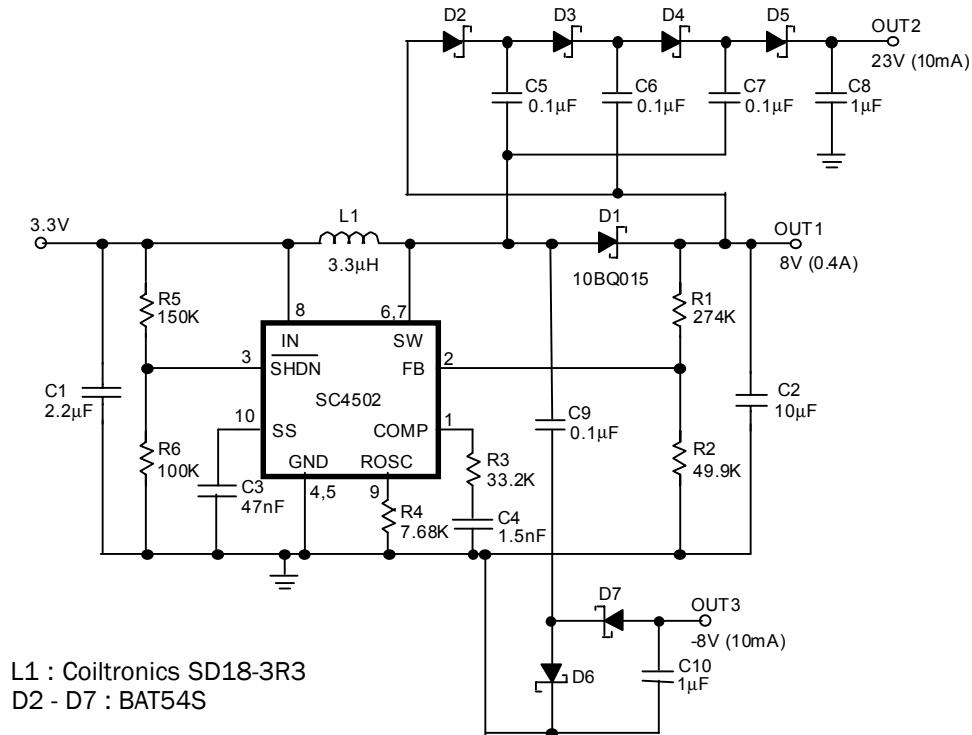
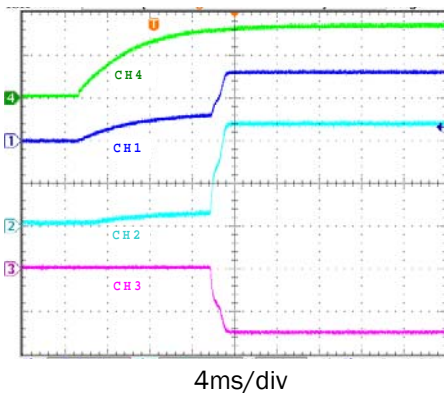
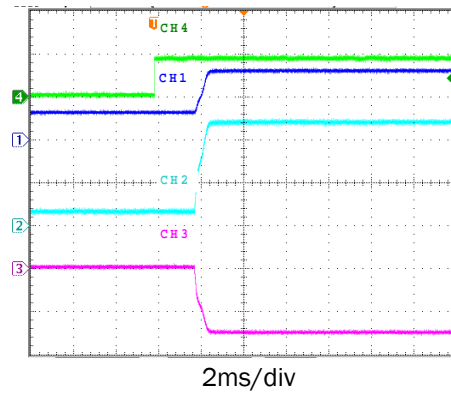

Figure 12(a). 1.5MHz Triple-Output TFT Power Supply.



CH1 : OUT1 Voltage, 5V/div
CH2 : OUT2 Voltage, 10V/div
CH3 : OUT3 Voltage, 5V/div
CH4 : Input Voltage, 2V/div

Figure 12(b). TFT Power Supply V_{IN} Start-up Transient.



CH1 : OUT1 Voltage, 5V/div
CH2 : OUT2 Voltage, 10V/div
CH3 : OUT3 Voltage, 5V/div
CH4 : SHDN Voltage, 2V/div

Figure 12(c). TFT Power Supply Start-up Transient as the SHDN Pin is stepped from 0 to 2V.

POWER MANAGEMENT

Typical Application Circuits

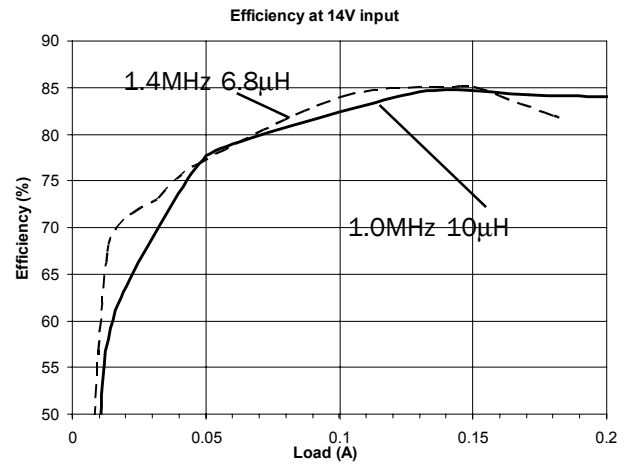
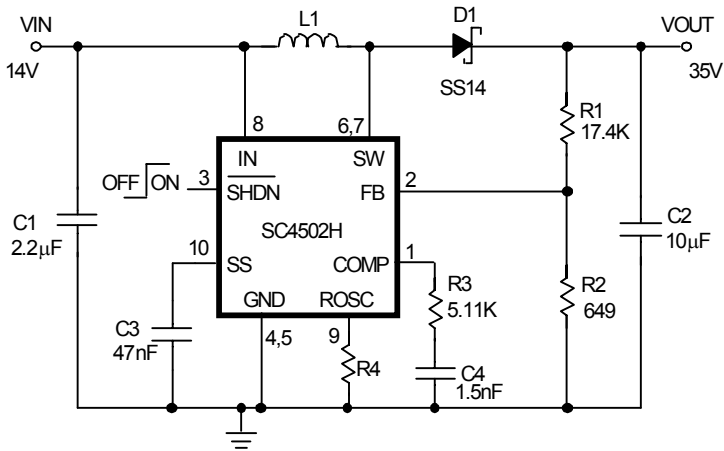

Figure 13(a). All Ceramic Capacitor High Voltage Application

Figure 13(b). Efficiency of the All Ceramic Capacitor High Voltage Application

f (MHz)	R_4 (K Ω)	L_1
1.0	15.8	10uH IHLP-2525BD_01
1.4	10	6.8uH IHLP-2525BD_01

POWER MANAGEMENT

Outline Drawing - MLPD-10, 3 x 3mm

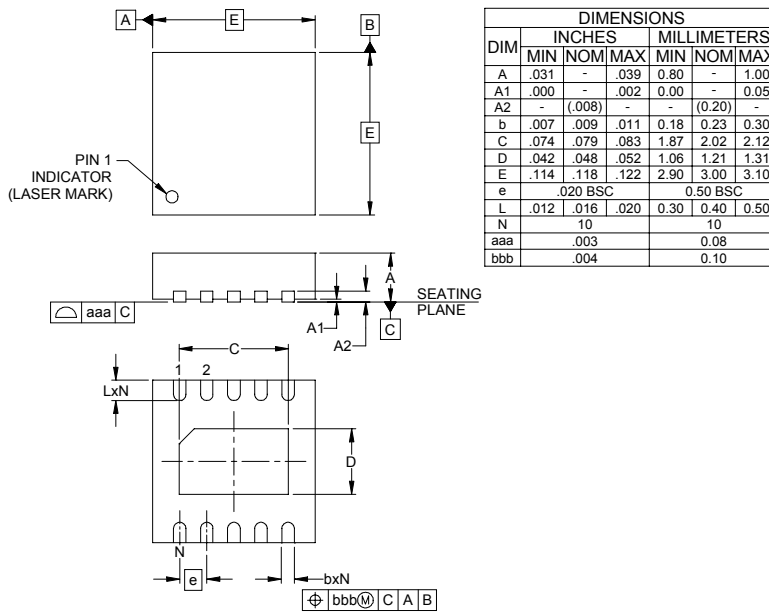

- NOTES:
1. CONTROLLING DIMENSIONS ARE IN MILLIMETERS (ANGLES IN DEGREES).
 2. COPLANARITY APPLIES TO THE EXPOSED PAD AS WELL AS TERMINALS.

Land Pattern - MLPD-10, 3 x 3mm

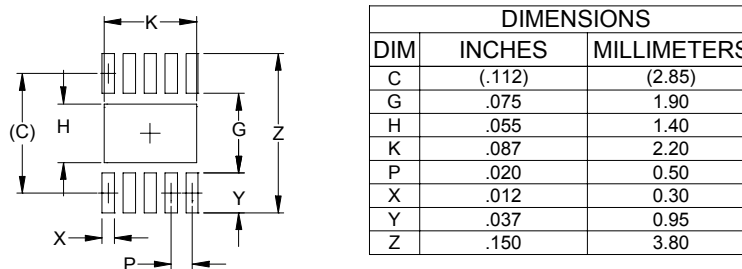

- NOTES:
1. THIS LAND PATTERN IS FOR REFERENCE PURPOSES ONLY. CONSULT YOUR MANUFACTURING GROUP TO ENSURE YOUR COMPANY'S MANUFACTURING GUIDELINES ARE MET.

Contact Information

Semtech Corporation
 Power Management Products Division
 200 Flynn Road, Camarillo, CA 93012
 Phone: (805)498-2111 FAX (805)498-3804